



PCD10120P

1200V Silicon Carbide Diode

Features

- 1200-Volt Schottky Rectifier
- Shorter recovery time
- High-speed switching possible
- High-Frequency Operation
- Temperature-Independent Switching Behavior
- Extremely Fast Switching
- Positive Temperature Coefficient on VF
- RoHS Compliant

Applications

- Switch Mode Power Supplies
- Power Factor Correction
- Motor Drives
- Uninterruptible Power Supply
- Solar Inverter
- EV Charger

Package Outline

PKG : TO-247 2L

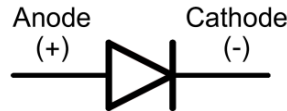

Absolute Maximum Ratings

T_C = 25°C unless otherwise noted

Symbol	Parameter	Value	Units	
V _{RRM}	Repetitive Peak Reverse Voltage	1200	V	
V _{RSM}	Surge Peak Reverse Voltage	1200	V	
V _{DC}	DC Blocking Voltage	1200	V	
I _F	Continuous Forward Current	T _C = 25°C T _C = 140°C	23 10	A
I _{FRM}	Repetitive Peak Forward Current	T _C = 110°C	55	A
I _{FSM}	Non-Repetitive Forward Surge Current (PW=10ms sinusoidal)	T _C = 25°C T _C = 110°C	80 64	A
P _D	Power Dissipation	T _C = 25°C	100	W
T _J , T _{stg}	Operating Junction and Storage Temperature		-55 to +175	°C

Electrical Characteristics

$T_C = 25^\circ\text{C}$ unless otherwise noted

Symbol	Parameter	Test Conditions	Min	Typ	Max	Units
V_F	Forward Voltage	$I_F = 10\text{A}, T_C = 25^\circ\text{C}$ $I_F = 10\text{A}, T_C = 175^\circ\text{C}$	--	1.45 2.0	1.75 2.4	V
I_R	Reverse Current	$V_R = 1200\text{V}, T_C = 25^\circ\text{C}$ $V_R = 1200\text{V}, T_C = 175^\circ\text{C}$	--	10 50	200 -	μA
Q_C	Total Capacitive Charge	$V_R = 800\text{V}$	--	61	--	nC
C	Total Capacitance	$V_R = 1\text{V}, T_J = 25^\circ\text{C}, f = 1\text{MHz}$ $V_R = 800\text{V}, T_J = 25^\circ\text{C}, f = 1\text{MHz}$	--	571 46	--	pF

Thermal Characteristics

$T_C = 25^\circ\text{C}$ unless otherwise noted

Symbol	Parameter	Min	Typ	Max	Units
$R_{\theta JC}$	Thermal Resistance, Junction-to-Case	--	1.5	1.8	$^\circ\text{C}/\text{W}$

Typical Characteristics

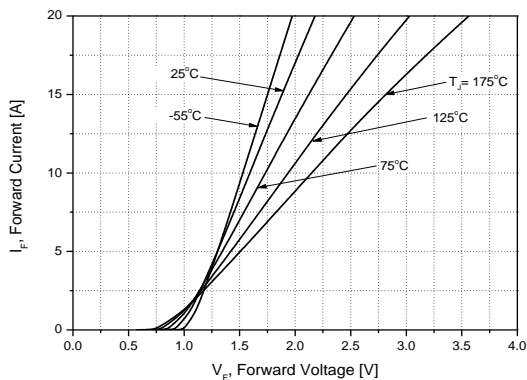

Figure 1. Forward Characteristics

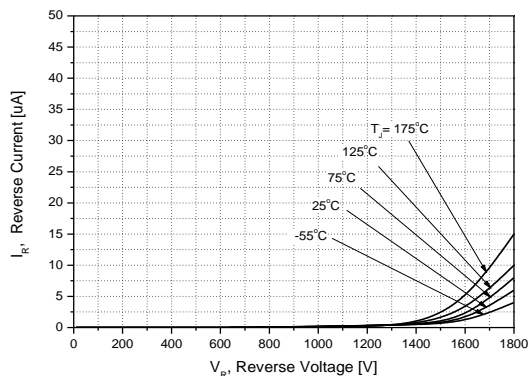

Figure 2. Reverse Characteristics

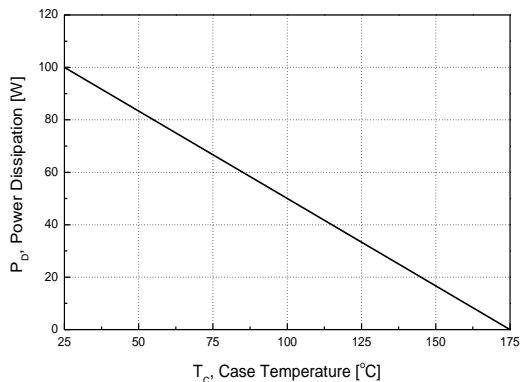

Figure 3. Power Dissipation

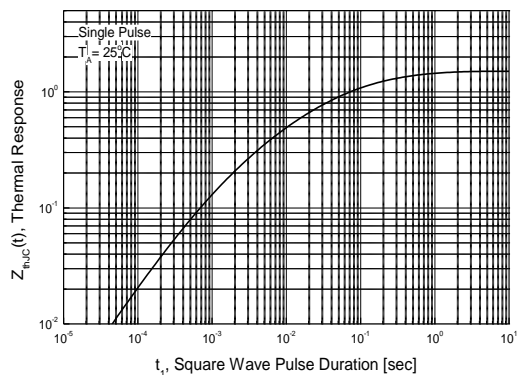

Figure 4. Transient Thermal Resistance

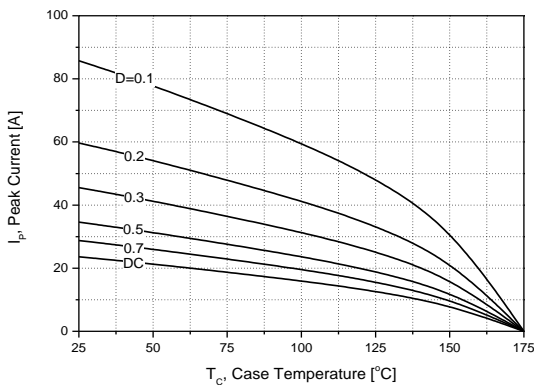

Figure 5. Peak Forward Current Derating

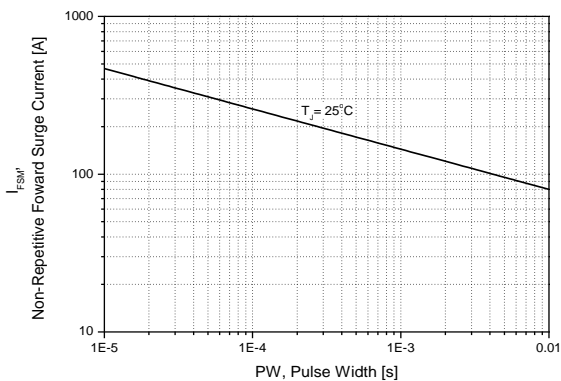

Figure 6. Non-Repetitive Peak Forward Surge Current vs. Pulse Duration

Typical Characteristics

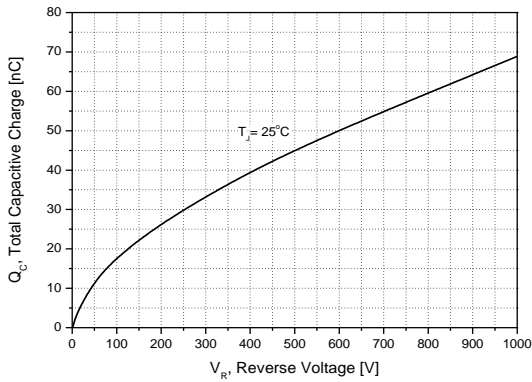

Figure 7. Total Capacitive Charge

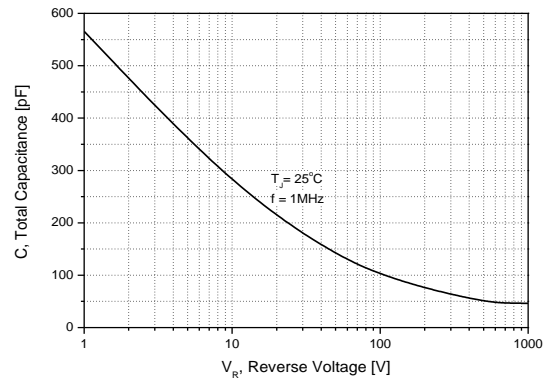

Figure 8. Total Capacitance

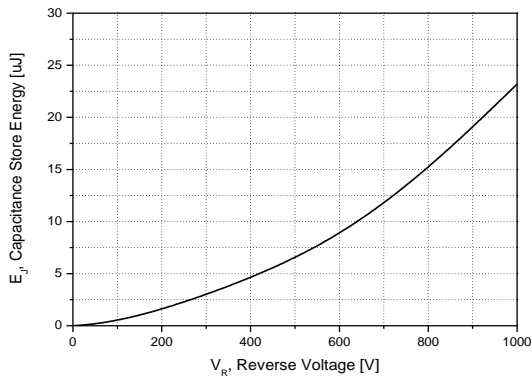

Figure 9. Capacitance Store Energy

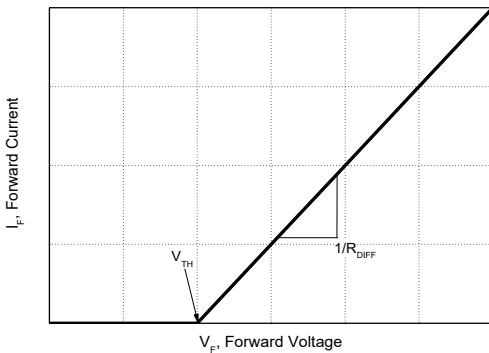

Figure 10. Equivalent Forward Current Curve

$$V_F = V_{TH} + R_{DIFF} \times I_F$$

Threshold Voltage (V_{TH})

$$V_{TH}(T_j) = -0.001 \times (T_j) + 0.950 \text{ [V]}$$

Differential Resistance (R_{DIFF})

$$R_{DIFF}(T_j) = A \times T_j^2 + B \times T_j + C \text{ [\Omega]}$$

$$A = 1.37 \times 10^{-6}$$

$$B = 2.69 \times 10^{-4}$$

$$C = 5.10 \times 10^{-2}$$

$$[T_j \text{ [}^\circ\text{C]}; -55 \text{ }^\circ\text{C} \leq T_j \leq 175 \text{ }^\circ\text{C}; I_F \leq 10 \text{ A}]$$

Package Information

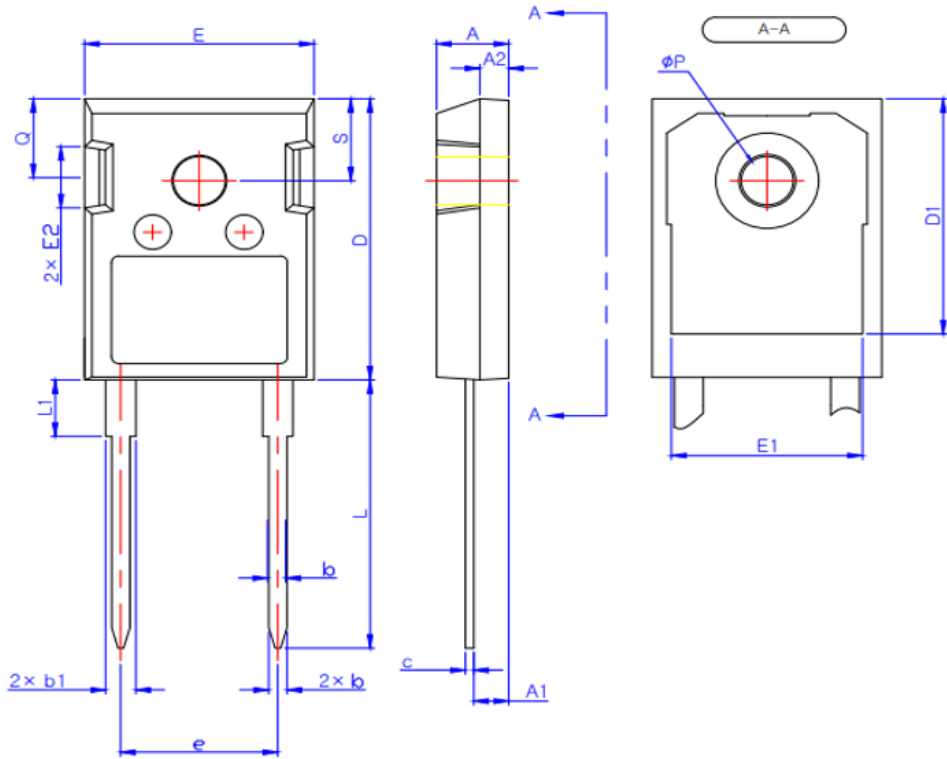

*

SYMBOL	MIN	MAX
A	4.80	5.20
A1	2.29	2.54
A2	1.90	2.10
b	1.10	1.30
b1	1.91	2.20
c	0.50	0.70
D	20.80	21.34
D1	17.43	17.83
E	15.75	16.13
E1	13.06	13.46
E2	4.32	4.83
e	10.90 BSC	
L	19.85	20.25
L1	-	4.49
ϕP	3.55	3.65
Q	5.59	6.19
S	6.15 BSC	

NOTE

1. THESE DIMENSION DO NOT INCLUDE MOLD PROTRUSION