



PCD30120B

1200V Silicon Carbide Diode

Features

- 1200-Volt Schottky Rectifier
- Shorter recovery time
- High-speed switching possible
- High-Frequency Operation
- Temperature-Independent Switching Behavior
- Extremely Fast Switching
- Positive Temperature Coefficient on VF
- RoHS Compliant

Applications

- Switch Mode Power Supplies
- Power Factor Correction
- Motor Drives
- Uninterruptible Power Supply
- Solar Inverter
- EV Charger

Package Outline

PKG : TO-247

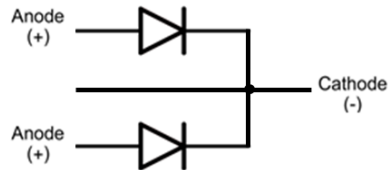
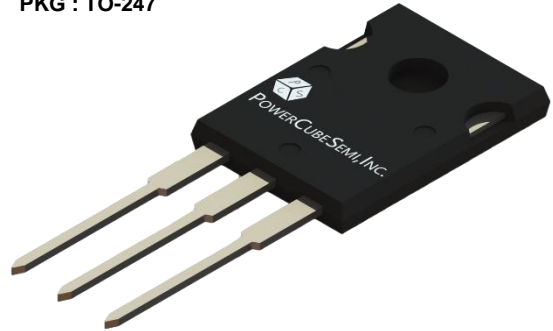

Absolute Maximum Ratings

$T_C = 25^\circ\text{C}$ unless otherwise noted

Symbol	Parameter	Value	Units
V_{RRM}	Repetitive Peak Reverse Voltage	1200	V
V_{RSM}	Surge Peak Reverse Voltage	1200	V
V_{DC}	DC Blocking Voltage	1200	V
I_F	Continuous Forward Current $T_C = 25^\circ\text{C}$ $T_C = 145^\circ\text{C}$	38 / 76 15 / 30	A
I_{FRM}	Repetitive Peak Forward Current $T_C = 110^\circ\text{C}$	89 / 178	A
I_{FSM}	Non-Repetitive Forward Surge Current (PW=10ms sinusoidal) $T_C = 25^\circ\text{C}$ $T_C = 110^\circ\text{C}$	120 / 240 96 / 192	A
P_D	Power Dissipation $T_C = 25^\circ\text{C}$	174 / 348	W
T_J, T_{stg}	Operating Junction and Storage Temperature	-55 to +175	$^\circ\text{C}$

* Per Leg / Per Device

Electrical Characteristics (Per Leg)

$T_C = 25^\circ\text{C}$ unless otherwise noted

Symbol	Parameter	Test Conditions	Min	Typ	Max	Units
V_F	Forward Voltage	$I_F = 15\text{A}, T_C = 25^\circ\text{C}$ $I_F = 15\text{A}, T_C = 175^\circ\text{C}$	--	1.45 2.0	1.75 2.4	V
I_R	Reverse Current	$V_R = 1200\text{V}, T_C = 25^\circ\text{C}$ $V_R = 1200\text{V}, T_C = 175^\circ\text{C}$	--	10 50	200 -	μA
Q_C	Total Capacitive Charge	$V_R = 800\text{V}$	--	88	--	nC
C	Total Capacitance	$V_R = 1\text{V}, T_J = 25^\circ\text{C}, f = 1\text{MHz}$ $V_R = 800\text{V}, T_J = 25^\circ\text{C}, f = 1\text{MHz}$	--	844 70	--	pF

Thermal Characteristics

$T_C = 25^\circ\text{C}$ unless otherwise noted

Symbol	Parameter	Min	Typ	Max	Units
$R_{\theta JC}$	Thermal Resistance, Junction-to-Case	--	0.86 / 0.43	1.03 / 0.47	$^\circ\text{C}/\text{W}$

* Per Leg / Per Device

Package Marking and Ordering Information

Device Marking	Device	Package	Reel Size	Tape Width	Quantity
P2CD30120B	P2CD30120	TO-247_3L	-	-	30

* P2CD30120B : RoHS Compliant

Typical Characteristics (Per Leg)

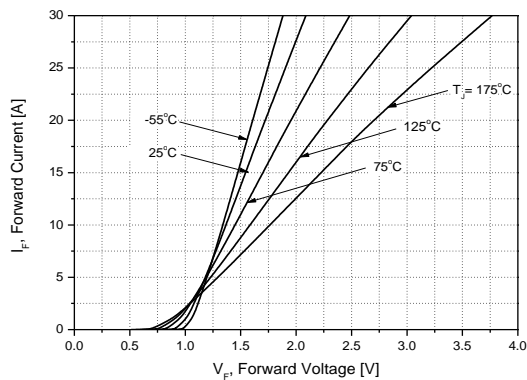

Figure 1. Forward Characteristics

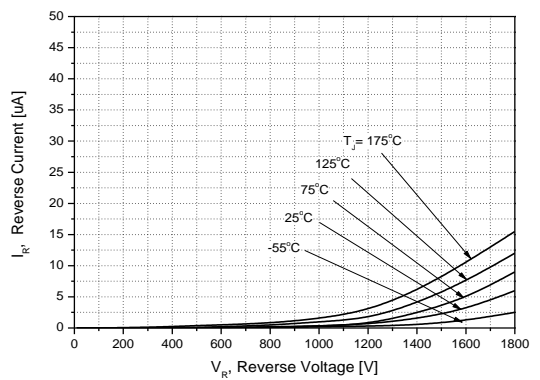

Figure 2. Reverse Characteristics

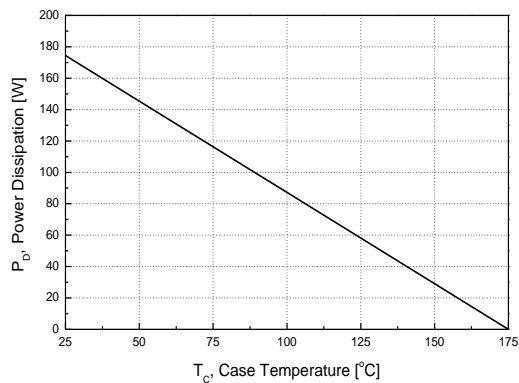

Figure 3. Power Dissipation

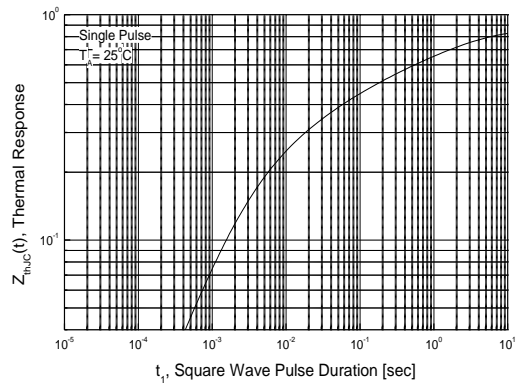

Figure 4. Transient Thermal Resistance

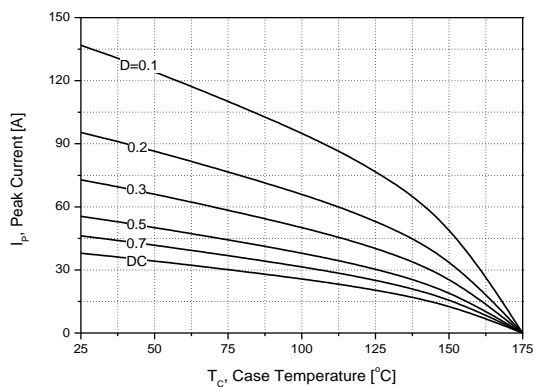

Figure 5. Peak Forward Current Derating

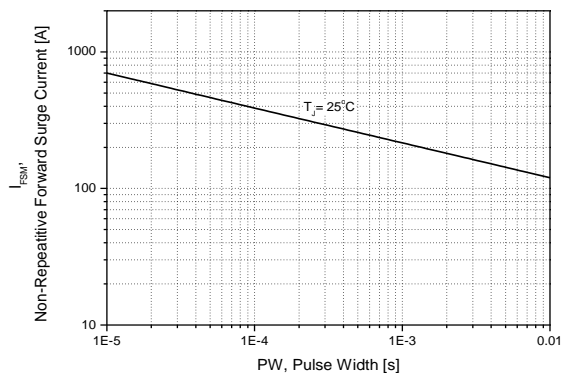

Figure 6. Non-Repetitive Peak Forward Surge Current vs. Pulse Duration

Typical Characteristics (Per Leg)

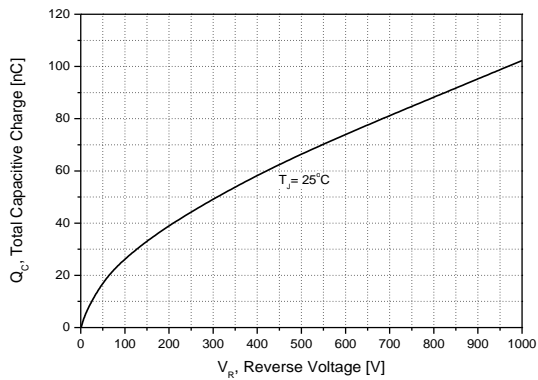

Figure 7. Total Capacitive Charge

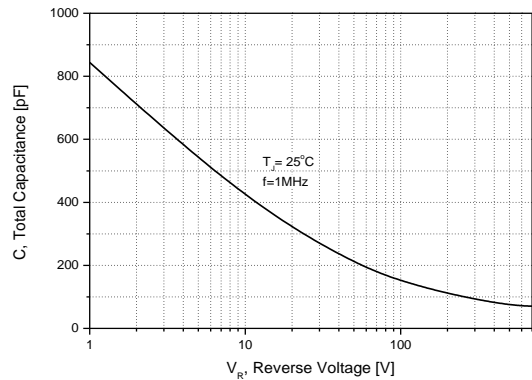

Figure 8. Total Capacitance

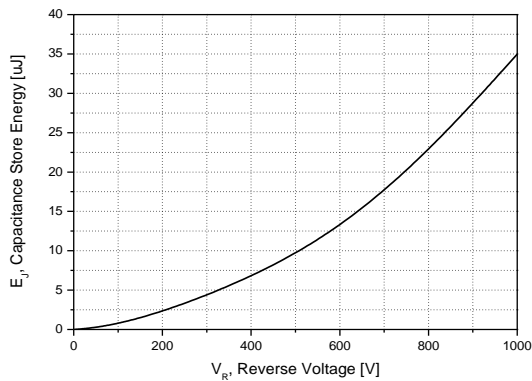

Figure 9. Capacitance Store Energy

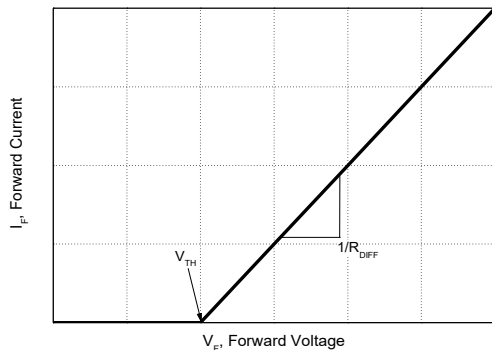

Figure 10. Equivalent Forward Current Curve

$$V_F = V_{TH} + R_{DIFF} \times I_F$$

Threshold Voltage (V_{TH})

$$V_{TH}(T_j) = -0.001 \times (T_j) + 0.950 \text{ [V]}$$

Differential Resistance (R_{DIFF})

$$R_{DIFF}(T_j) = A \times T_j^2 + B \times T_j + C \text{ [}\Omega\text{]}$$

$$A = 9.54 \times 10^{-7}$$

$$B = 2.12 \times 10^{-4}$$

$$C = 3.04 \times 10^{-2}$$

$$[T_j \text{ [}^\circ\text{C]}; -55 \text{ }^\circ\text{C} \leq T_j \leq 175 \text{ }^\circ\text{C}; I_F \leq 15 \text{ A}]$$

Package Information

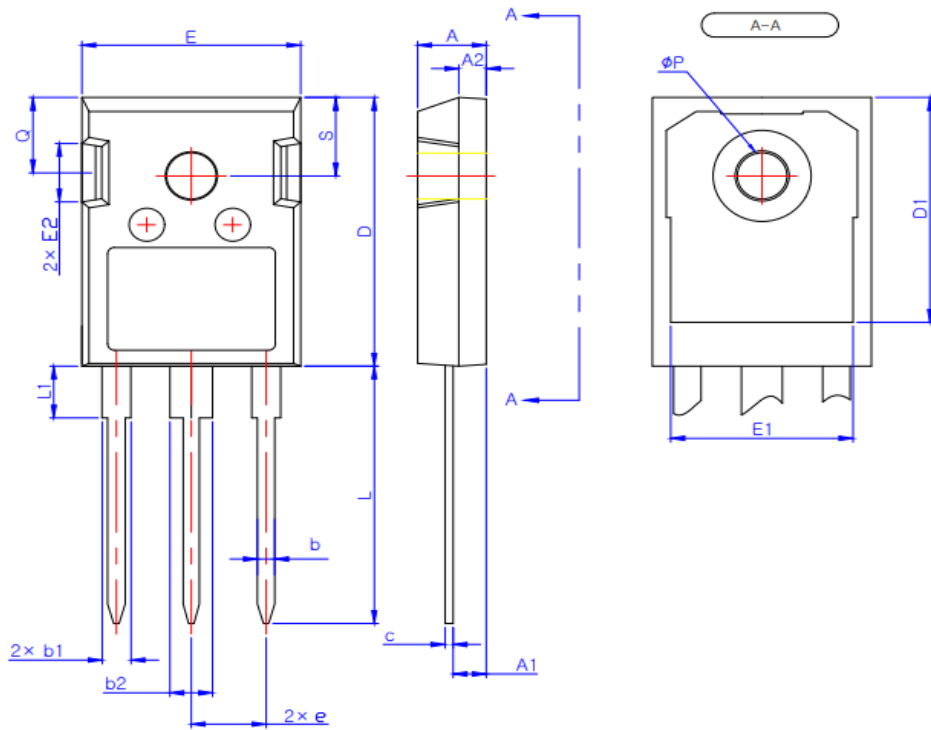

★

SYMBOL	MIN	MAX
A	4.80	5.20
A1	2.29	2.54
A2	1.90	2.10
b	1.10	1.30
b1	1.91	2.20
b2	2.92	3.20
c	0.50	0.70
D	20.80	21.34
D1	17.43	17.83
E	15.75	16.13
E1	13.06	13.46
E2	4.32	4.83
e	5.45 BSC	
L	19.85	20.25
L1	-	4.49
phi P	3.55	3.65
Q	5.59	6.19
S	6.15 BSC	

NOTE

1. THESE DIMENSION DO NOT INCLUDE MOLD PROTRUSION