

# PGT200N080G

80V 176A 2.0mΩ Si N-channel Enhancement Mode Split gate MOSFET

## Features

### Si N channel Enhancement Mode Split gate MOSFET

- Rated to 80V at 176Amps @ $T_C = 25^\circ\text{C}$
- Max  $R_{DS(on)} = 2.3\text{ m}\Omega$
- Gate Charge(Typ.  $Q_G=105\text{ nC}$ )
- Surface-mounted package
- Low Thermal Resistance
- Super Trench
- MSL1

## Application

- Motor Drivers
- DC-DC Converter

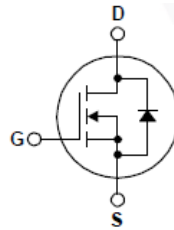
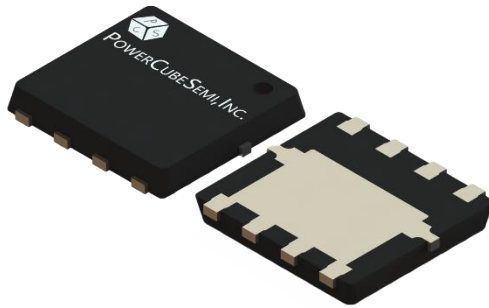

PKG type : PDFN5060-8L

## Absolute Maximum Ratings

$T_C=25^\circ\text{C}$  Unless Otherwise Noted

Symbol	Parameter	Test Condition	Value	Unit
$BV_{DSS}$	Drain-Source Breakdown Voltage	$V_{GS}=0V, I_D=250\mu A$	80	V
$I_D^{*, **}$	Drain Current	$V_{GS}=10V, T_C=25^\circ\text{C}$	176	A
$I_{DM}^{*, **, ***}$	Pulsed Drain Current	$V_{GS}=10V, T_C=25^\circ\text{C}$	400	A
$V_{GS}$	Gate-Source Voltage	$T_C=25^\circ\text{C}$	$\pm 20$	V
$E_{AS}^*$	Single Pulsed Avalanche Energy	$V_{DD}=50V, L=1.0mH$	512	mJ
$P_D^*$	Power Dissipation	$T_C=25^\circ\text{C}$	300	W
$T_J$	Junction Temperature		175	$^\circ\text{C}$
$T_{stg}$	Storage Temperature		-55 to 175	$^\circ\text{C}$
$R_{\theta JA}^*$	Thermal Resistance – Junction to Ambient		55	$^\circ\text{C}/\text{W}$
$R_{\theta JC}^*$	Thermal Resistance – Junction to Case		0.5	$^\circ\text{C}/\text{W}$

### Note :

- \* Surface Mounted on 1 in<sup>2</sup> pad area,  $t \leq 10\text{ sec.}$
- \*\* Pulse Width  $\leq 300\mu s$ , duty cycle  $\leq 1\%$
- \*\*\* Limited by bonding wire

## Electrical Characteristics

$T_C=25^\circ\text{C}$  Unless Otherwise Noted

### Static Characteristics

Symbol	Parameter	Test Condition	Numerical			Unit
			Min	Typ.	Max.	
$BV_{DSS}$	Drain-Source Breakdown Voltage	$V_{GS} = 0V, I_D = 250\mu A$	80	-	-	V
$V_{GS(th)}$	Gate Threshold Voltage	$V_{DS} = V_{GS}, I_D = 250\mu A$	2	-	4	V
$I_{DSS}$	Drain-Source Leakage Current	$V_{DS} = 64V, V_{GS} = 0V$	-	-	1	$\mu A$
$I_{GSS}$	Gate-Source Leakage Current	$V_{GS} = \pm 20V, V_{DS} = 0V$	-	-	$\pm 100$	nA
$R_{DS(ON)}$	Static Drain-Source on state Resistance	$V_{GS} = 10V, I_D = 60A$	-	2.0	2.3	m $\Omega$

### Dynamic Characteristics

Symbol	Parameter	Test Condition	Numerical			Unit
			Min	Typ.	Max.	
$C_{iss}$	Input Capacitance	$V_{GS}=0V, V_{DS}=40V, f=1\text{MHz}$	-	5531	-	pF
$C_{oss}$	Output Capacitance		-	845	-	
$C_{rss}$	Reverse Transfer Capacitance		-	62	-	
$T_{d(on)}$	Turn-On Delay Time	$V_{DS}=40V, V_{GEN}=10V, R_G=3.9\Omega, R_L=0.66\Omega, I_{DS}=60A$	-	21	-	ns
$T_r$	Turn-On Rise Time		-	78	-	
$T_{d(off)}$	Turn-Off Delay Time		-	63	-	
$T_f$	Turn-Off Rise Time		-	53	-	

### Gate Charge Characteristics

Symbol	Parameter	Test Condition	Numerical			Unit
			Min	Typ.	Max.	
$Q_G$	Total Gate Charge	$V_{DS}=40V, V_{GS}=10V, I_{DS}=60A$	-	105	-	nC
$Q_{GS}$	Gate-Source Charge		-	31	-	
$Q_{GD}$	Gate-Drain Charge		-	28	-	

### Diode Characteristics

Symbol	Parameter	Test Condition	Numerical			Unit
			Min	Typ.	Max.	
$V_{SD}$	Diode Forward Voltage	$I_{SD}=60A, V_{GS}=0V$	-	-	1.3	V
$T_{rr}$	Reverse Recovery Time	$I_{SD}=60A, di_{SD}/dt=100A/\mu s$	-	40	-	ns
$Q_{rr}$	Reverse Recovery Charge		-	38	-	nC

## Package Marking and Ordering Information

Device Marking	Device	Package	Packing Method	Tape width	Quantity
PGT200N080G	PGT200N080	PDFN5060	-	-	5000 unit

## Pin Description

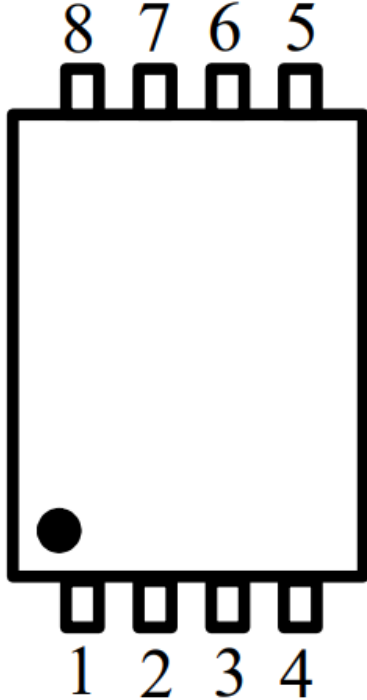
Pin	Description	Simplified Outline
1, 2, 3	Source (S)	
4	Gate (G)	
5, 6, 7, 8	Drain (D)	

# Typical Characteristics

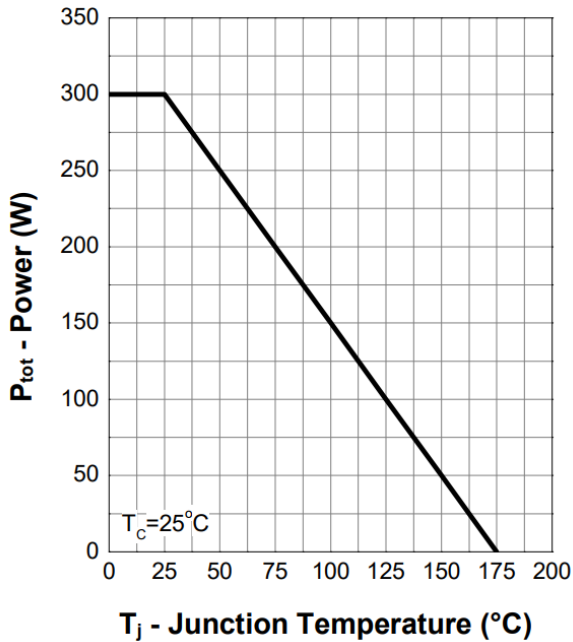

Figure 1. Power Capability

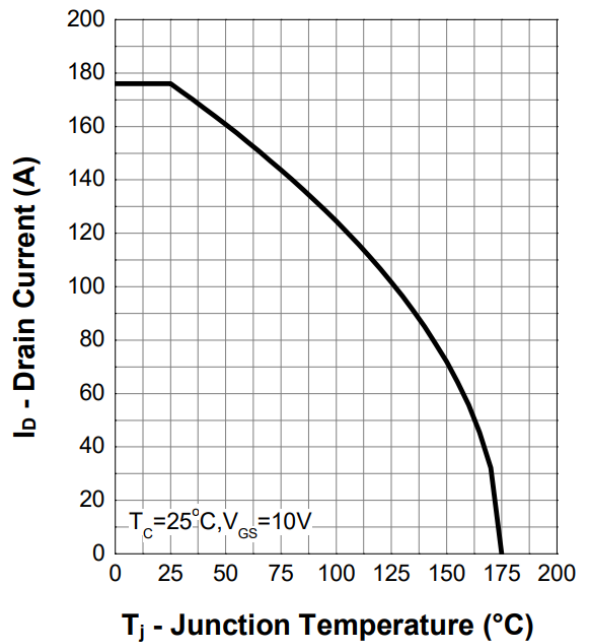

Figure 2. Current Capability

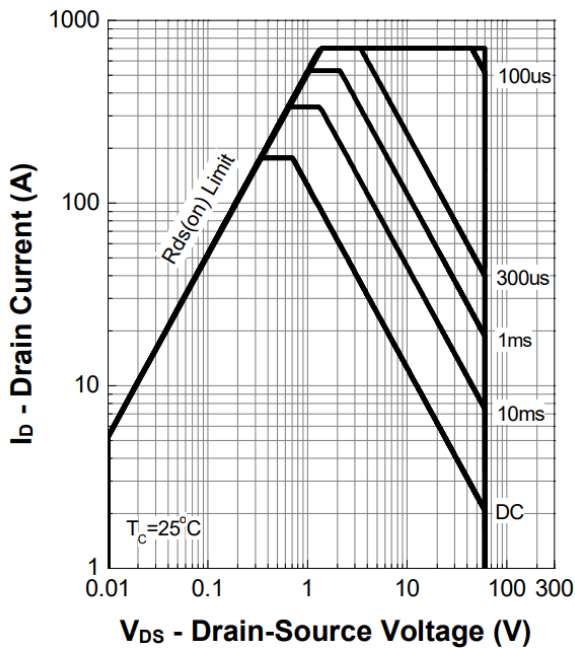

Figure 3. Safe Operating Area

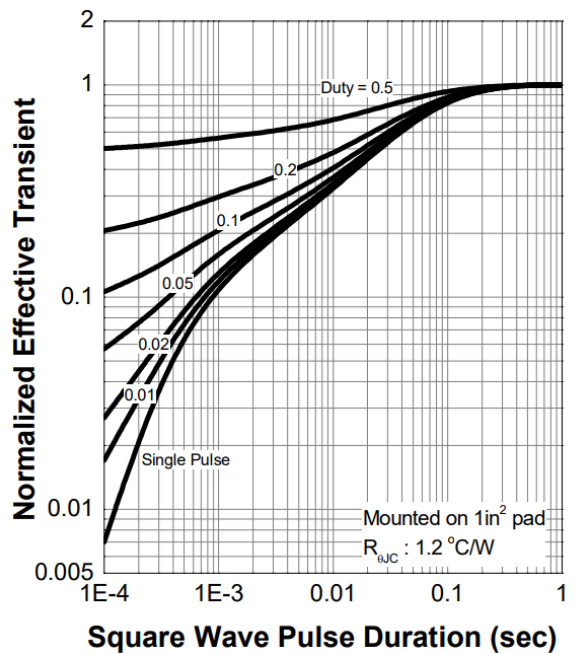

Figure 4. Transient Thermal Impedance

# Typical Characteristics

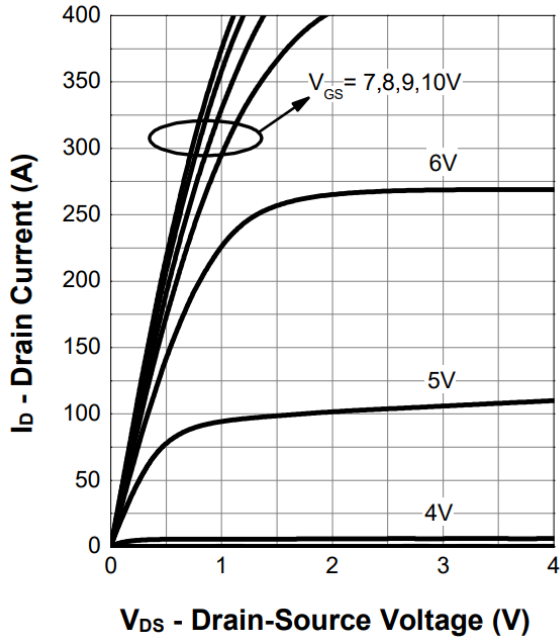

Figure 5. Output Characteristics

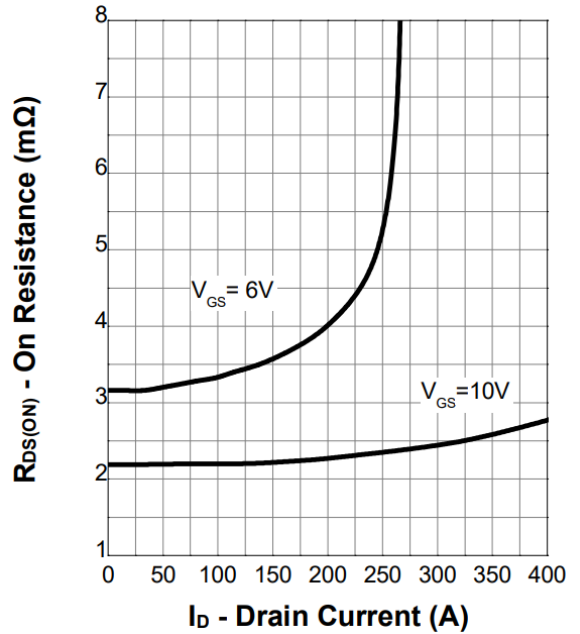

Figure 6. On-Resistance

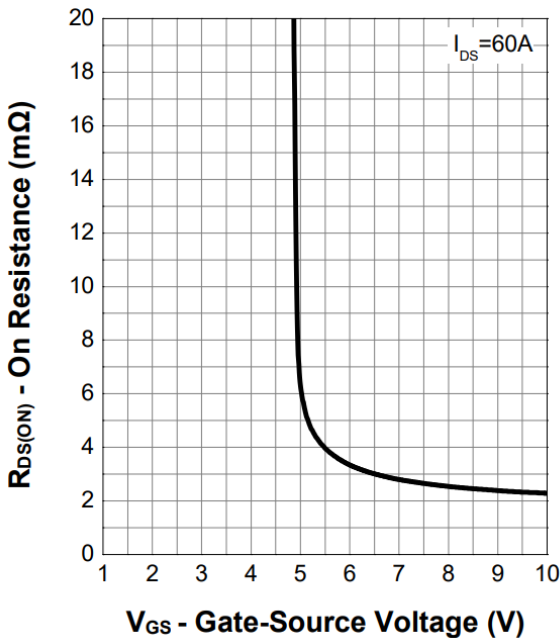

Figure 7. Transfer Characteristics

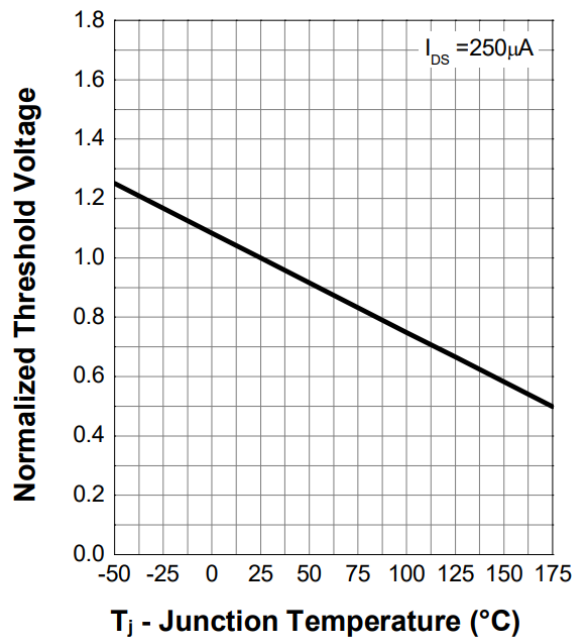

Figure 8. Normalized Threshold Voltage

# Typical Characteristics

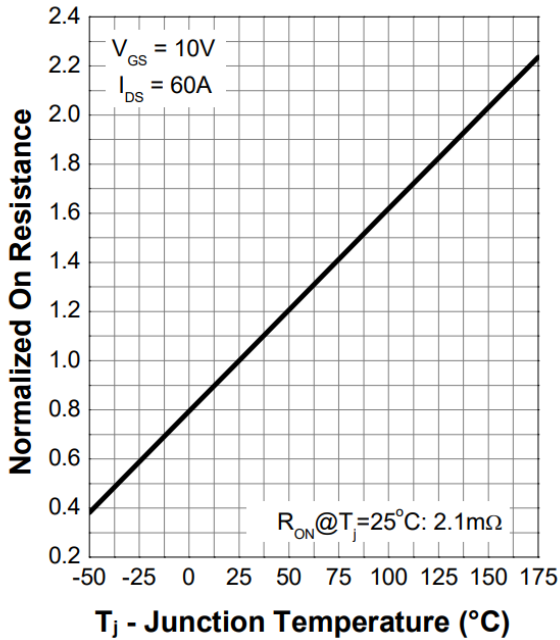

Figure 9. Normalized On-Resistance

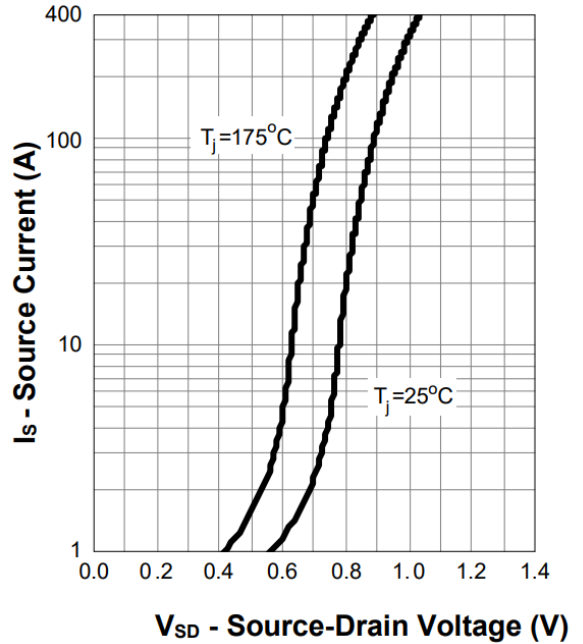

Figure 10. Diode Forward Current

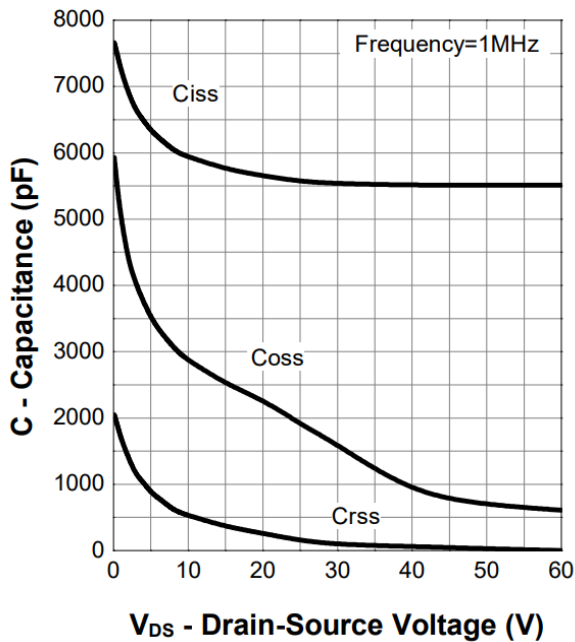

Figure 11. Capacitance

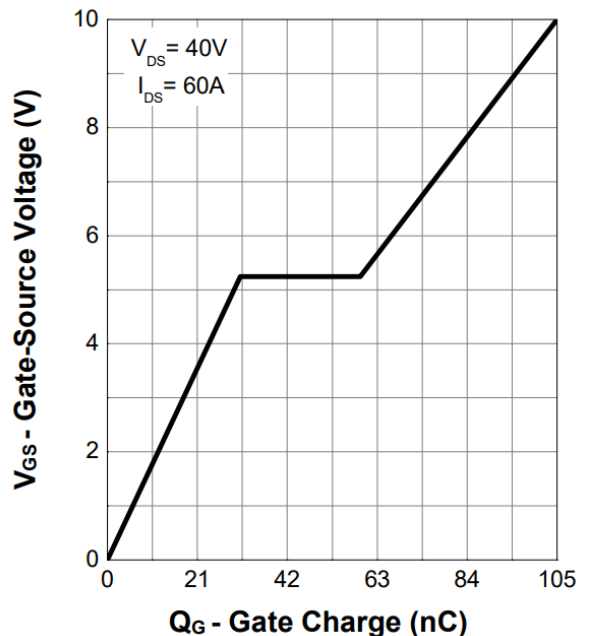
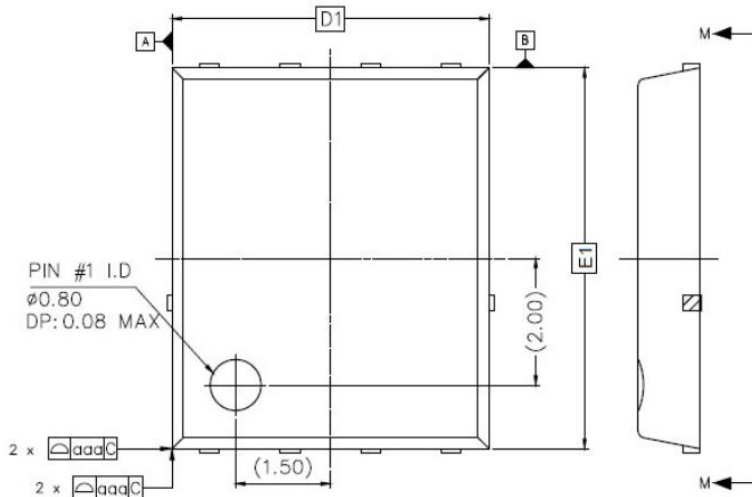

Figure 12. Gate Charge

## Package Outline

Unit : mm



SYMBOL	DIMENSION		NOTES
	MIN	MAX	
A	0.95	1.05	
A1	0.00	0.05	
A3	0.254 REF		
b	0.31	0.51	
b1	0.03	0.13	
b2	0.21	0.41	
D	5.15 BSC		
D1	5.00 BSC		
D2	3.70	3.90	
E	6.15 BSC		
E1	6.00 BSC		
E2	3.56	3.76	
e	1.27 BSC		
L	0.51	0.71	
M	0.51	0.71	
P	10°	12°	
aaa	0.10		
bbb	0.10		
ccc	0.10		
ddd	0.05		
eee	0.08		

