

PM008N085GG

85V 65A 8.5mΩ Si Single N-ch Enhancement Mode Power MOSFET with Normal Diode

Features

Si Single N-ch Enhancement Mode Power MOSFET

- Rated to 85V at 65Amps @ $T_j = 25^\circ\text{C}$
- Max $R_{DS(on)} = 8.5\text{ m}\Omega$
- Typ $R_{DS(on)} = 7\text{ m}\Omega$
- Gate Charge(Typ. $Q_g=39\text{ nC}$)
- 100% Avalanche Tested

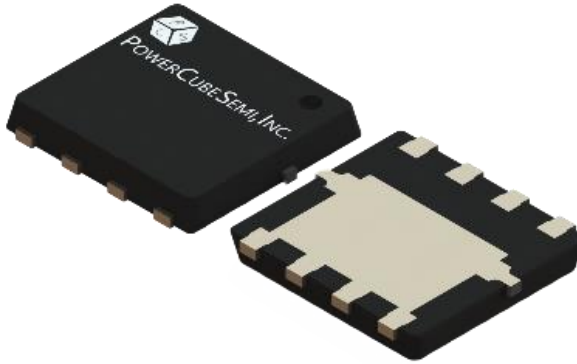

PKG type : DFN5X6-8L

Application

- Power switch
- DC-DC Converters

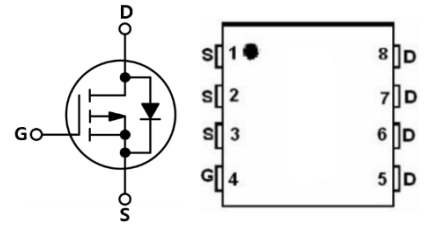

Description

The PM008N085GG uses advanced trench technology to provide excellent $R_{DS(ON)}$, low gate charge. it can be used in a wide variety of applications.

Absolute Maximum Ratings

Symbol	Parameter	Test Condition	Value	Unit
BV_{DSS}	Drain-Source Breakdown Voltage	$V_{GS}=0V, I_D=250\mu A$	85	V
I_D	Drain Current	$T_c=25^\circ\text{C}$	65	A
I_{DM}	Pulsed Drain Current	Pulse width limited by junction temperature	260	A
V_{GS}	Gate-Source Voltage		± 20	V
E_{AS}	Single Pulsed Avalanche Energy	$V_{DD}=50V, V_{GS}=10V, L=0.5mH, R_G=25\Omega$	81	mJ
P_d	Power Dissipation	$T_c=25^\circ\text{C}$	69	W
T_j	Operating Junction Temperature		150	$^\circ\text{C}$
T_{stg}	Storage Temperature		-55 to 150	$^\circ\text{C}$

Package Marking and Ordering Information

Device Marking	Device	Package	Packing Method	Tape width	Quantity
PN008N085GG	PN008N085	PDFN56	REEL	-	5000

Electrical Characteristics of Si MOSFET

Symbol	Parameter	Test Condition	Numerical			Unit
			Min	Typ.	Max.	
BV_{DSS}	Drain-Source Breakdown Voltage	$V_{GS} = 0V, I_D = 250\mu A, T_J = 25^\circ C$	85	-	-	V
I_{DSS}	Zero Gate Voltage Drain Current	$V_{DS} = 85V, V_{GS} = 0V$	-	-	1	μA
I_{GSS}	Gate-Source Leakage Current	$V_{GS} = \pm 20V, V_{DS} = 0V$	-	-	± 100	nA
$V_{GS(th)}$	Gate Threshold Voltage	$V_{DS} = V_{GS}, I_D = 250\mu A$	2.0	3.0	4.0	V
$R_{DS(ON)}$	Static Drain-Source on state resistance	$V_{GS} = 10V, I_D = 20A$	-	7	8.5	m Ω
g_{FS}	Forward Transconductance	$V_{DS} = 5V, I_D = 20A$	-	34	-	S
$t_{d(on)}$	Turn-on Delay time	$V_{DD} = 40V, I_D = 20A, R_G = 3\Omega$	-	17	-	ns
T_r	Turn-on Rise time		-	4	-	
$t_{d(off)}$	Turn-off Delay time		-	32	-	
T_f	Turn-off Fall time		-	8	-	



Electrical Characteristics of Si MOSFET

Symbol	Parameter	Test Condition	Numerical		Unit
			Typ.	Max.	
$R_{\theta JC}$	Thermal Resistance, Junction to Case		1.8	-	$^{\circ}\text{C}/\text{W}$
C_{iss}	Input Capacitance	$V_{DS} = 40\text{V}, V_{GS} = 0\text{V},$ $f = 1.0\text{MHz}$	1682	-	pF
C_{oss}	Output Capacitance		540	-	
C_{rss}	Reverse Transfer Capacitance		26	-	
$Q_{g(\text{tot})}$	Total Gate Charge at 10V	$V_{DD} = 40\text{V}, I_D = 20\text{A}$ $V_{GS(\text{on})} = 10\text{V}$	39	-	nC
Q_{gs}	Gate to Source Gate Charge		8.1	-	
Q_{gd}	Gate to Drain "Miller" Charge		10.5	-	

Electrical Characteristics of Si Diode

Symbol	Parameter	Test Condition	Numerical		Unit
			Typ.	Max.	
I_S	Maximum Continuous Drain to Source Diode Forward Current		-	65	A
V_{SD}	Drain to Source Diode Forward Voltage	$I_{SD} = 20\text{A}, V_{GS} = 0\text{V}$	-	1.2	V
T_{rr}	Reverse Recovery Time	$I_F = 20\text{A}, V_{GS} = 0\text{V},$ $di_F/dt = 100\text{A}/\mu\text{s}$	50.4	-	ns
Q_{rr}	Reverse Recovery Charge		68	-	nC

Typical Characteristics

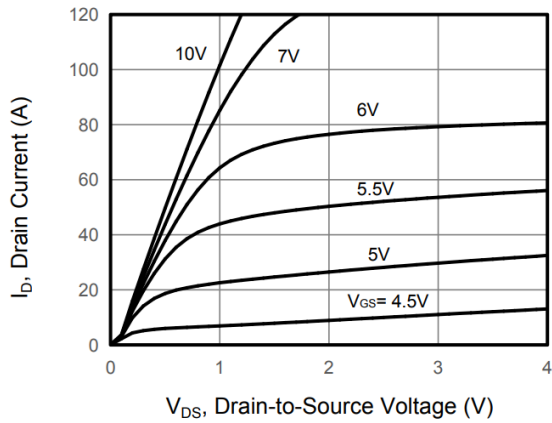

Figure 1. Output Characteristics

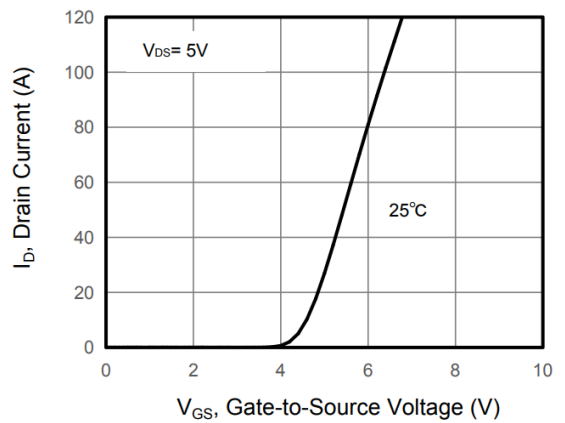

Figure 2. Transfer Characteristics

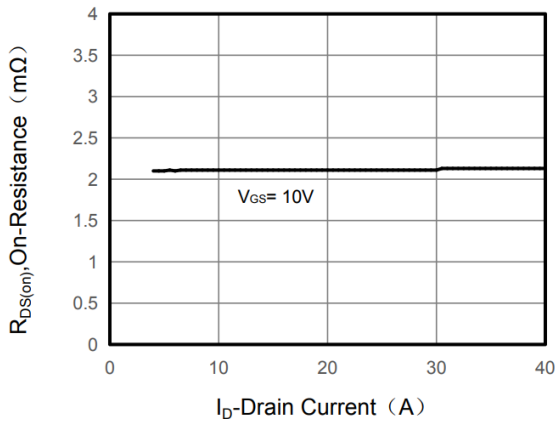

Figure 3. Drain to Source On-Resistance

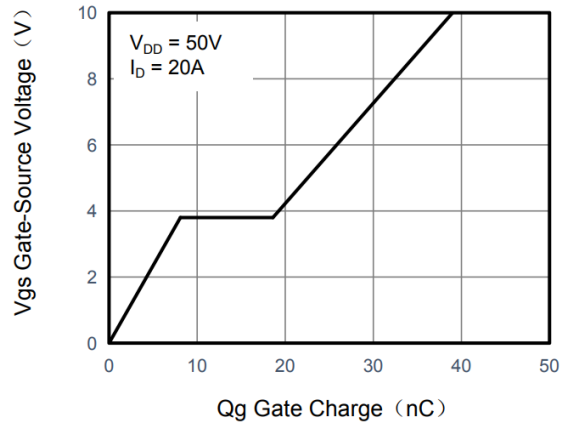

Figure 4. Gate Charge

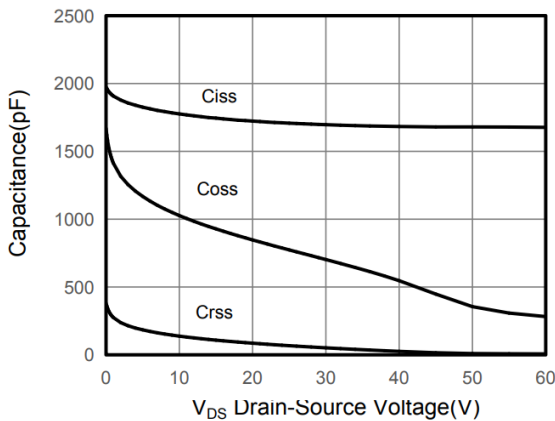

Figure 5. Capacitance Characteristics

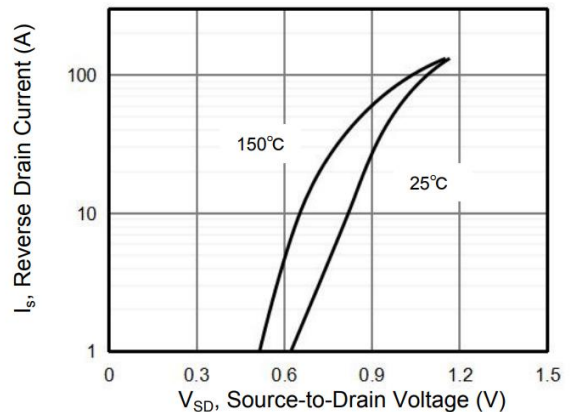

Figure 6. Source to Drain Diode Forward

Typical Characteristics

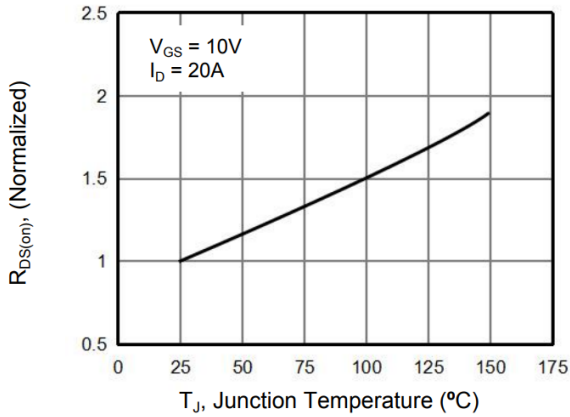

Figure 7. Drain to Source On-Resistance

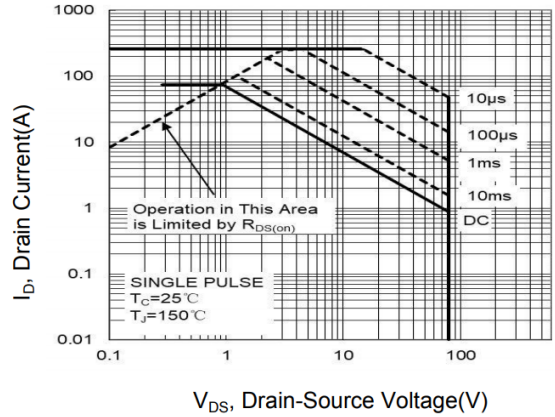

Figure 8. Safe Operation Area

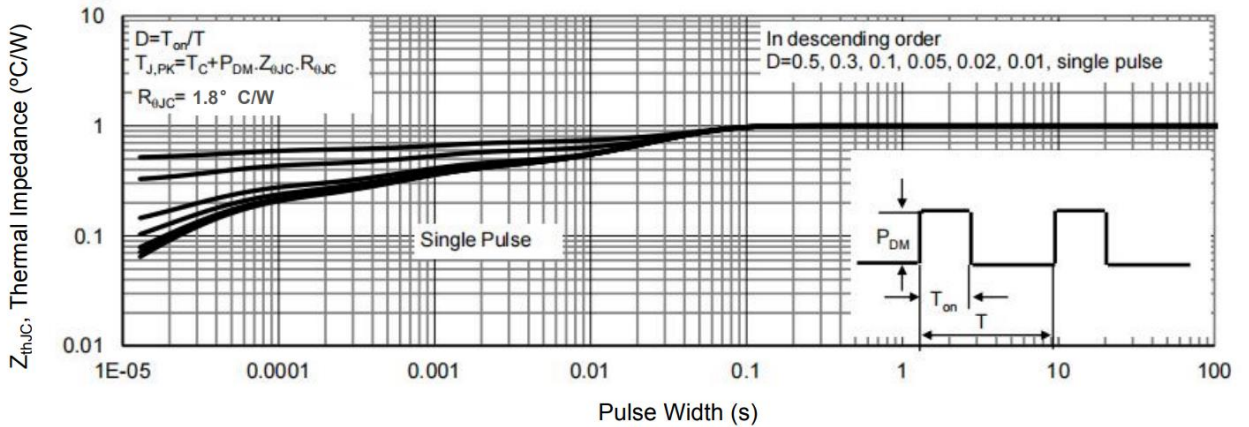
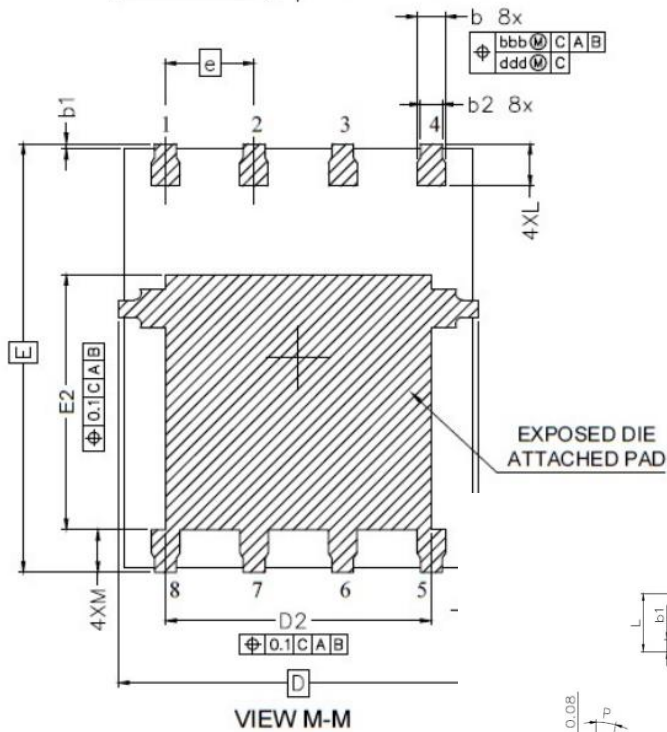
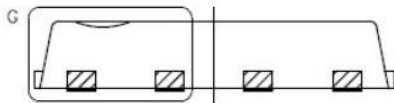
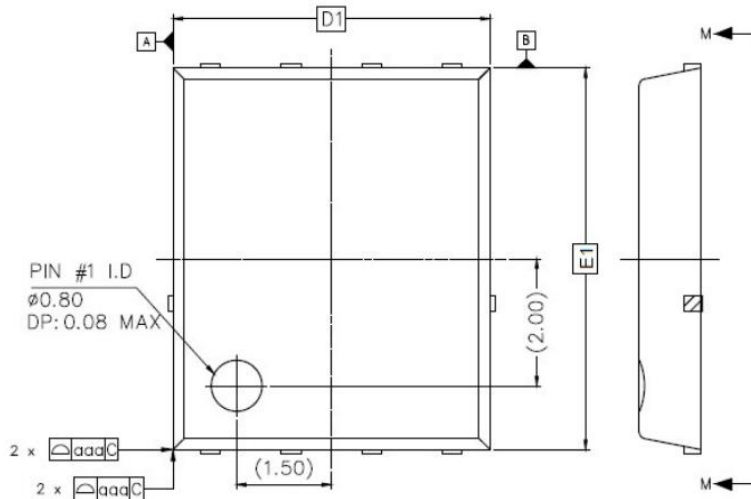

Figure 9. Normalized Maximum Transient Thermal Impedance

Package Outline

Unit : mm



VIEW M-M

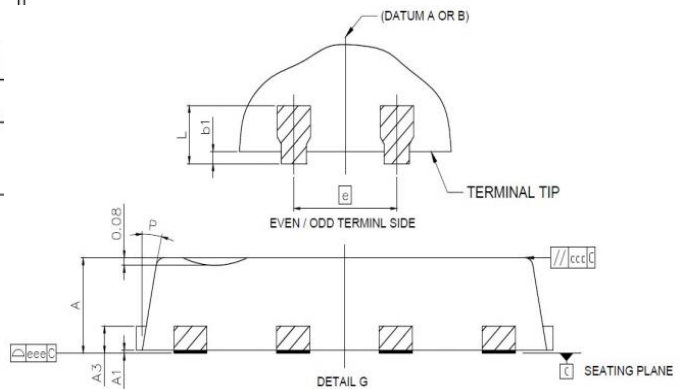

SYMBOL	DIMENSION	
	MIN	MAX
A	0.95	1.05
A1	0.00	0.05
A3	0.254 REF	
b	0.31	0.51
b1	0.03	0.13
b2	0.21	0.41
D	5.15 BSC	
D1	5.00 BSC	
D2	3.70	3.90
E	6.15 BSC	
E1	6.00 BSC	
E2	3.56	3.76
e	1.27 BSC	
L	0.51	0.71
M	0.51	0.71
P	10°	12°
aaa	0.10	
bbb	0.10	
ccc	0.10	
ddd	0.05	
eee	0.08	